

USER GUIDE

DCX3200

User Guide



IMPORTANT SAFETY INSTRUCTIONS

- Read these instructions.
- Keep these instructions.
- Heed all warnings.
- Follow all instructions.
- Do not use this apparatus near water.
- Clean only with dry cloth.
- Do not block any ventilation openings. Install in accordance with the manufacturers instructions.
- Do not install near any heat sources such as radiators, heat registers, stoves, or other apparatus (including amplifiers) that produce heat.
- Do not defeat the safety purpose of the polarized or grounding-type plug. A polarized plug has two blades with one wider than the other. A grounding type plug has two blades and a third grounding prong. The wide blade or the third prong is provided for your safety. If the provided plug does not fit into your outlet, consult an electrician for replacement of the obsolete outlet.
- Protect the power cord from being walked on or pinched particularly at plugs, convenience receptacles, and the point where they exit from the apparatus.
- Only use attachments/accessories specified by the manufacturer.
- Unplug this apparatus during lightning storms or when unused for long periods of time.
- Refer all servicing to qualified service personnel. Servicing is required when the apparatus has been damaged in any way, such as the power-supply cord or plug is damaged, liquid has been spilled or objects have fallen into the apparatus, the apparatus has been exposed to rain or moisture, does not operate normally, or has been dropped.

IMPORTANT SAFETY CONSIDERATIONS

- The plug is the main disconnect device. It shall remain readily accessible and operable.
- The apparatus shall not be exposed to dripping or splashing and no objects filled with liquids, such as vases, shall be placed on the apparatus.

During Transportation to the Subscriber Home

- Transport the cable terminal in its shipping box or an equally padded container.
- Do not expose the terminal to rain or moisture.

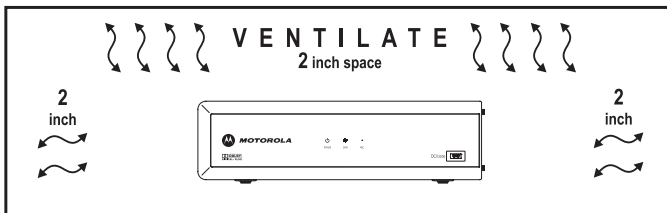

During Installation

- Do not place the terminal in an enclosed area where the cooling vents are blocked or impede the flow of air through the ventilation openings.
- Install the terminal so that its position does not interfere with its proper ventilation. For example, do not place the terminal on a bed, sofa, rug, or similar surface that could block the ventilation openings.
- Install the terminal away from heat sources such as radiators, heat registers and stoves. Installation of the terminal near consumer electronics devices, such as stereo receiver/amplifiers and televisions, is permitted as long as the air surrounding the terminal does not exceed 40° C (104° F).
- Place the terminal on a flat surface not prone to vibration or impact.
- Do not install the terminal in an area where condensation occurs.
- To prevent the temporary loss of guide data and cause a temporarily non-responding terminal, do not plug the AC power cord into a switched power outlet.

FCC COMPLIANCE

Note: This equipment has been tested and found to comply with the limits for a Class B digital device, pursuant to part 15 of the FCC Rules. These limits are designed to provide reasonable protection against harmful interference in a residential installation. This equipment generates uses and can radiate radio frequency energy and, if not installed and used in accordance with the instructions, may cause harmful interference to radio communications. However, there is no guarantee that interference will not occur in a particular installation. If this equipment does cause harmful interference to radio or television reception, which can be determined by turning the equipment off and on, the user is encouraged to try to correct the interference by one or more of the following measures:

- Reorient or relocate the receiving antenna.
- Increase the separation between the equipment and receiver.
- Connect the equipment into an outlet on a circuit different from that to which the receiver is connected.
- Consult the dealer or an experienced radio/TV technician for help.

Caution: Changes or modifications not expressly approved by Motorola for compliance could void the user's authority to operate the equipment.

This device complies with part 15 of the FCC Rules. Operation is subject to the following two conditions: (1) This device may not cause harmful interference, and (2) this device must accept any interference received, including interference that may cause undesired operation.

FCC DECLARATION OF CONFORMITY

Motorola Inc., Home & Network Mobility, 101 Tournament Drive, Horsham, PA 19044, 1-215-323-1000, declares that the DCX 3200 set-top complies with 47 CFR Parts 2 and 15 of the FCC rules as a Class B digital device.

Canada Industry Canada (IC)

This Class B digital device complies with Canadian ICES-003.

Cet appareil numérique de la classe B est conforme à la norme NMB-003 du Canada.

CARING FOR THE ENVIRONMENT BY RECYCLING



When you see this symbol on a Motorola product, do not dispose of the product with residential or commercial waste.

Recycling your Motorola Equipment

Please do not dispose of this product with your residential or commercial waste. Some countries or regions, such as the European Union, have set up systems to collect and recycle electrical and electronic waste items. Contact your local authorities for information about practices established for your region. If collection systems are not available, call Motorola Customer Service for assistance.

SOFTWARE LICENSE

IMPORTANT: PLEASE READ THIS SOFTWARE LICENSE (“LICENSE”) CAREFULLY BEFORE YOU USE ANY SOFTWARE, FIRMWARE AND RELATED DOCUMENTATION (“SOFTWARE”) PROVIDED WITH MOTOROLA’S DIGITAL CABLE RECEIVER OR HOME THEATER SYSTEM (EACH SHALL BE REFERRED TO IN THIS LICENSE AS A “RECEIVER”). BY USING THE RECEIVER AND/OR USING ANY OF THE SOFTWARE, YOU INDICATE YOUR ACCEPTANCE OF EACH OF THE TERMS OF THIS LICENSE. UPON ACCEPTANCE, THIS LICENSE WILL BE A LEGALLY BINDING AGREEMENT BETWEEN YOU AND MOTOROLA. THE TERMS OF THIS LICENSE APPLY TO YOU AND TO ANY SUBSEQUENT USER OF THIS SOFTWARE.

IF YOU DO NOT AGREE TO ALL OF THE TERMS OF THIS LICENSE (I) DO NOT USE THE SOFTWARE AND (II) RETURN THE RECEIVER AND THE SOFTWARE (COLLECTIVELY, “PRODUCT”), INCLUDING ALL COMPONENTS, DOCUMENTATION AND ANY OTHER MATERIALS PROVIDED WITH THE PRODUCT, TO YOUR POINT OF PURCHASE OR SERVICE PROVIDER, AS THE CASE MAY BE, FOR A FULL REFUND.

The Software includes associated media, any printed materials, and any “on-line” or electronic documentation. Software provided by third parties may be subject to separate end-user license agreements from the manufacturers of such Software. The Software is never sold. Motorola licenses the Software to the original customer and to any subsequent licensee for personal use only on the terms of this License. Motorola and its third party licensors retain the ownership of the Software.

You may:

USE the Software only in connection with the operation of the Product.

TRANSFER the Software (including all component parts and printed materials) permanently to another person, but only if the person agrees to accept all of the terms of this License. If you transfer the Software, you must at the same time transfer the Product and all copies of the Software (if applicable) to the same person or destroy any copies not transferred.

TERMINATE this License by destroying the original and all copies of the Software (if applicable) in whatever form.

You may not:

(1) Loan, distribute, rent, lease, give, sublicense or otherwise transfer the Software, in whole or in part, to any other person, except as permitted under the TRANSFER paragraph above. (2) Copy or translate the User Guide included with the Software, other than for personal use. (3) Copy, alter, translate, decompile, disassemble or reverse engineer the Software, including but not limited to, modifying the Software to make it operate on non-compatible hardware. (4) Remove, alter or cause not to be displayed, any copyright notices or startup message contained in the Software programs or documentation. (5) Export the Software or the Product components in violation of any United States export laws.

The Product is not designed or intended for use in on-line control of aircraft, air traffic, aircraft navigation or aircraft communications; or in design, construction, operation or maintenance of any nuclear facility. MOTOROLA AND ITS THIRD PARTY LICENSORS DISCLAIM ANY EXPRESS OR IMPLIED WARRANTY OF FITNESS FOR SUCH USES. YOU REPRESENT AND WARRANT THAT YOU SHALL NOT USE THE PRODUCT FOR SUCH PURPOSES.

Title to this Software, including the ownership of all copyrights, mask work rights, patents, trademarks and all other intellectual property rights subsisting in the foregoing, and all adaptations to and modifications of the foregoing shall at all times remain with Motorola and its third party licensors. Motorola retains all rights not expressly licensed under this License. The Software, including any images, graphics, photographs, animation, video, audio, music and text incorporated therein is owned by Motorola or its third party licensors and is protected by United States copyright laws and international treaty provisions. Except as otherwise expressly provided in this License, the copying, reproduction, distribution or preparation of derivative works of the Software, any portion of the Product or the documentation is strictly prohibited by such laws and treaty provisions. Nothing in this License constitutes a waiver of Motorola's rights under United States copyright law.

This License and your rights regarding any matter it addresses are governed by the laws of the Commonwealth of Pennsylvania, without reference to conflict of laws principles. THIS LICENSE SHALL TERMINATE AUTOMATICALLY if you fail to comply with the terms of this License.

Motorola is not responsible for any third party software that is provided as a bundled application, or otherwise, with the Software or that is downloaded to, or otherwise installed on, the Product.

U.S. GOVERNMENT RESTRICTED RIGHTS

The Product and documentation is provided with RESTRICTED RIGHTS. The use, duplication or disclosure by the Government is subject to restrictions as set forth in subdivision (c)(1)(ii) of The Rights in Technical Data and Computer Software clause at 52.227-7013. The contractor/manufacturer is Motorola, Inc., Home & Network Mobility, 101 Tournament Drive, Horsham, PA 19044.

© 2008 Motorola, Inc. All rights reserved. No part of this publication may be reproduced in any form or by any means or used to make any derivative work (such as translation, transformation, or adaptation) without written permission from Motorola, Inc.

MOTOROLA and the Stylized M logo are registered in the US Patent and Trademark Office. CableCARD™, M-Card™, and DOCSIS® are trademarks or registered trademarks of Cable Television Laboratories, Inc. HDMI, the HDMI Logo and HighDefinition Multimedia Interface are trademarks or registered trademarks of HDMI Licensing LLC. Manufactured under license from Dolby Laboratories. "Dolby," "Pro Logic," and the double-D symbol are trademarks of Dolby Laboratories. Macrovision is a registered trademark of Macrovision Corporation. All other product or service names are the property of their respective owners. All rights reserved.

© Copyright 2008 Multimedia over Coax Alliance. All Rights Reserved. MoCA and the MoCA logo is a trademark of Multimedia over Coax Alliance. The Multimedia over Coax Alliance (MoCA), www.mocalliance.org, is an open, standard body promoting networking of digital video and entertainment through existing coaxial cable in the home.

Motorola reserves the right to revise this publication and to make changes in content from time to time without obligation on the part of Motorola to provide notification of such revision or change. Motorola provides this guide without warranty of any kind, implied or expressed, including, but not limited to, the implied warranties of merchantability and fitness for a particular purpose. Motorola may make improvements or changes in the product(s) described in this manual at any time



CONTENTS

1 Introduction	1
Front Panel.....	2
Rear Panel	3
2 Operation	5
Turning Power On and Off	5
Changing Channels.....	5
Adjusting the Volume.....	5
Interactive Program Guide	5
M-Card™.....	6
3 Connecting Your DCX set-top.....	7
Video Connection Options	7
Connecting HDTV — Single Connection for Video/Audio	9
Cable In	9
HDMI.....	9
IEEE-1394	9
Connecting Your DCX set-top to an HDTV — Single Connection for Video/Audio	10
Connecting HDTV — Separate Video/Audio Connections	11
Cable In	11
DVI.....	11
Component Video (YPbPr)	11
Audio.....	12
Connecting Your DCX Set-top to an HDTV — Separate Video/Audio	13
Connecting Your DCX Set-top to an HDTV — Alternative Audio	14
Connecting an A/V Receiver — Audio	15
Connecting Your DCX set-top to an A/V Receiver — Audio	16
Connecting an SDTV.....	17
Connecting Your DCX set-top to an SDTV	18
Connecting an SDTV and VCR/DVD Recorder	19
Connecting Your DCX set-top to an SDTV and VCR/DVD Recorder.....	20
Connecting an A/V Receiver, SDTV, and VCR/DVD Recorder	21
Connecting Your DCX set-top to an A/V Receiver, SDTV, and VCR/DVD Recorder.....	22
4 Recording Your Connections.....	23
Data Devices	24
Data Features.....	24

3 CONNECTING YOUR DCX SET-TOP

5 On-Screen Graphics	25
6 Configuring the Audio, Video, and Closed Caption Settings.....	27
7 Troubleshooting.....	41



1 INTRODUCTION

Congratulations on receiving a Motorola DCX3200 High-Definition All-Digital Cable Set-top box, one of the most advanced interactive digital cable set-tops available today. Motorola has merged the extraordinary features of digital cable — the seemingly endless programming options, interactive program guides, Video on Demand (VOD), commercial-free, CD quality music, and the incredible picture quality and sound of High-Definition TV (HDTV).

This set-top includes an “Entertainment Package” that enables a direct digital connection to consumer audio and video devices through IEEE-1394 and HDMI™ interfaces.

This User Guide introduces you to the basic features, outlines important safeguards, and provides several options for integrating this component into your current entertainment system. Please take a few moments to read through this User Guide; the configuration diagrams, on-screen menu description and troubleshooting section will help you make the most of your home entertainment experience.

To determine which features of digital cable are provided in your service area, please check with your local cable operator. They will be happy to provide instructions for these optional services.

Features

- Integrated MoCA™ networking (only available on DCX3200-M model)
- HDMI, Component, IEEE-1394, S-Video, Composite, RF remod, Digital Audio (S/PDIF), Audio L/R, Ethernet, USB
- 1080p 24/30 video decode & output support

1 INTRODUCTION

Front Panel

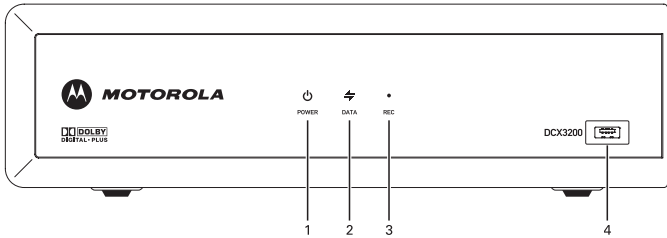

1	Power — Turns the set-top on and off (standby)
2	Data — Dual function LED <ul style="list-style-type: none">• LED alternates to indicate provisioning is on going• LED illuminates to indicate when one or more set-top boxes and associated DVR devices are detected on the home network
3	Rec — Unit is in record mode on a home network device (only available on DCX3200-M model) with MoCA option
4	USB connector

1 INTRODUCTION

Rear Panel

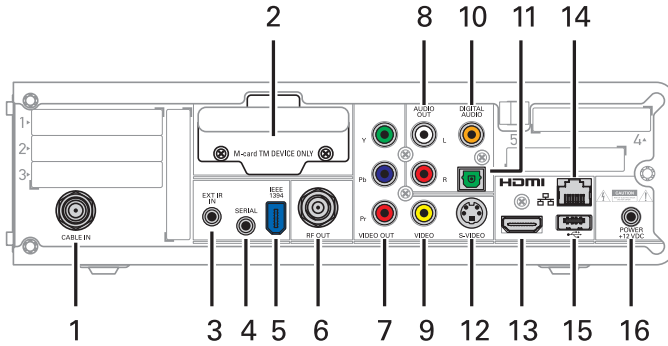

1	Cable In — Connects to cable signal from your service provider
2	M-Card — Inserted M-Card
3	External IR Input – Connects to a remote control IR receiver cable
4	Serial — Data test connector (service personnel only)
5	IEEE-1394 — Audio and video device connection
6	RF Out — Ch 3/4 modulated audio/video (SDTV) to TV or VCR
7	Video outputs / YPbPr — Component video output (HDTV)
8	Audio Out — L/R audio (SDTV)
9	Video Out — Composite Video (SDTV)
10	Digital Audio (Coaxial S/PDIF) — Provides Dolby® Digital Plus or PCM output
11	Digital Audio (Optical S/PDIF) — Provides Dolby® Digital Plus or PCM output
12	S-Video — Connects to S-Video (SDTV) input of TV or VCR
13	HDMI — High-Definition TV (HDTV) connector
14	Ethernet* — Network connection
15	USB* 2.0 — High-Speed peripheral device connection
16	Power connector

* Availability of certain features is dependent upon application support.



2 OPERATION

Turning Power On and Off

Press POWER on the remote control to turn the DCX set-top on or off (standby). Be sure the remote control is in cable mode by pressing CABLE before pressing POWER.

Changing Channels

You can change channels in three ways:

- Press CHANNEL + or – on the remote control to step through the channel selection.
- Enter the number of the channel you wish to view using the number keys on the remote control.
- Select the channel in the Interactive Program Guide.

Adjusting the Volume

Press VOLUME + or – on the remote control to adjust the volume. When you adjust the volume, the volume scale is displayed on the screen. Press MUTE on the remote control to toggle the sound on and off.

For best audio quality when using the analog L/R audio outputs, use the remote control to set the DCX set-top to approximately three quarters of the maximum volume level and then adjust the audio levels on external devices such as your TV or A/V receiver.

Interactive Program Guide

The Interactive Program Guide displays information about TV programs and enables you to access features such as Parental Control or Pay-Per-View. Interactive program guides can vary with each cable service provider. Refer to the Interactive Program Guide's instruction manual for detailed instructions.

2 OPERATION

M-Card™

The M-Card is required to view cable television programs and interactive on-demand programs. The M-Card should not be removed.



3 CONNECTING YOUR DCX SET-TOP

Instructions and diagrams are included for the following connections:

- High-Definition TV (HDTV)
- A/V receiver — Audio
- Standard-Definition TV (SDTV)
- Standard-Definition TV (SDTV) and VCR/DVD Recorder
- A/V receiver, Standard-Definition TV (SDTV), and VCR/DVD Recorder

Before you move or change components on your entertainment system, review the following:

- For basic cable connections, use 75-ohm coaxial cables equipped with F-type connectors
- Disconnect power from your equipment before connecting or changing cable connections

CAUTION!



Do not place anything on top of your DCX set-top, especially other home entertainment components. Be sure to provide adequate ventilation to prevent overheating.

Video Connection Options

The DCX set-top offers several different video connection options. Component video, HDMI, and IEEE-1394 allow you to view both High-Definition and Standard-Definition TV programming. Composite video, S-Video, and RF coaxial connections allow you to view only Standard-Definition TV programming.

To determine whether your TV features component video, HDMI, IEEE-1394, S-Video, or composite video, check the manual supplied with your TV.

Use the guidelines below to determine the best video connection for your home entertainment system.

Note: Only (1) video connection to the TV is required. HD video can only be viewed with HDMI, IEEE-1394, or component video connections.

3 CONNECTING YOUR DCX SET-TOP

- **HDMI or IEEE-1394 — HDTV and SDTV**

HDMI and IEEE-1394 offer higher quality HD video than component video.

If your TV has an HDMI input, this is for both audio and video. Connect a Standard HDMI cable to the TV and to the HDMI connector on your DCX set-top.

HDMI and IEEE-1394 outputs provide video and audio, so no separate audio connections are required if you plan to use your TV's speakers as the primary audio source.

On-screen graphics will not be displayed when you are using the IEEE-1394 connection on the rear panel of the DCX set-top. Refer to [Section 5](#) for more information.

If your TV has a DVI input, connect a DVI-to-HDMI adapter or cable to the HDMI out connector on the DCX set-top and the DVI-HDTV connector on your TV.

Note: DVI does not provide audio. A separate audio connection must be made.

- **Component video (YPbPr) — HDTV and SDTV**

The YPbPr connectors on your DCX set-top provide HDTV and SDTV component video.

Note: Component video does not provide audio. A separate audio connection must be made.

- **S-Video — SDTV**

If a component video input is not available on your TV, use the S-Video connection.

Note: S-Video does not provide audio. A separate audio connection must be made.

3 CONNECTING YOUR DCX SET-TOP

- **Composite Video (also referred to as Video) — SDTV**

If an S-Video input is not available on your TV, use the composite video (video) connection.

Note: Composite video does not provide audio. A separate audio connection must be made.

- **RF Output — SDTV**

If no other input is available on your TV, the RF Output of the DCX3200 can be connected to the Antenna or Cable Input on your TV. The RF Output carries both video and audio. Set your TV to channel 3 or 4.

Connecting HDTV — Single Connection for Video/Audio

Cable In

Connect an RF coaxial cable to the cable wall outlet and the CABLE IN connector on the DCX set-top.

HDMI

If your TV has an HDMI input, this is for both audio and video if you are using the TV speakers. Connect a Standard HDMI cable to the TV and to the HDMI connector on your DCX set-top.

IEEE-1394

If your HDTV has an IEEE-1394 connector, you can use the IEEE-1394 for both your video and audio connection. Connect an IEEE-1394 cable to the IEEE-1394 connector on your HDTV and DCX set-top.

Note: On-screen graphics will not be displayed when you are using the IEEE-1394 connection on the rear panel of the DCX set-top. Refer to [Section 5](#) for more information.

If you have an audio/video receiver and are not using your TV's speakers, go to [Connecting Your DCX Set-top to an A/V Receiver — Audio](#).

3 CONNECTING YOUR DCX SET-TOP

Connecting Your DCX Set-top to an HDTV — Single Connection for Video/Audio

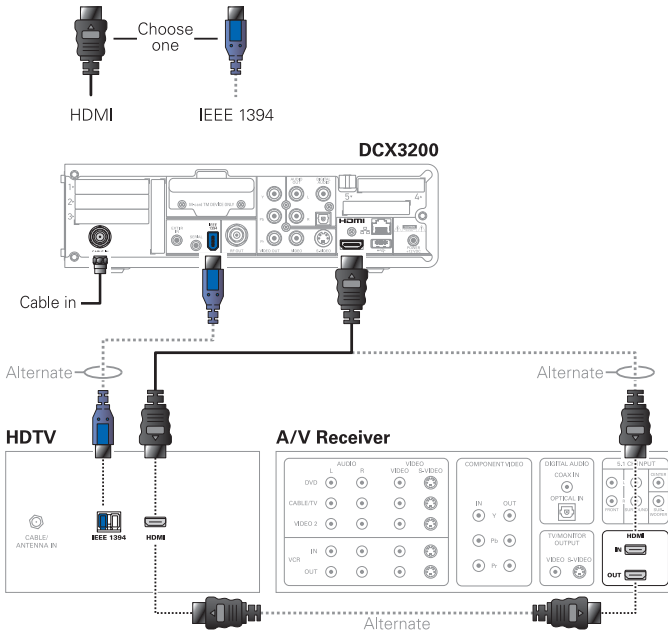

Note: Only (1) HDTV video/audio connection needs to be made to an HDTV.

Note: On screen graphics will not be displayed when using IEEE-1394 connection. Refer to [Section 5](#) for more information.

Note: Solid lines indicate optimum connections.

Note: Optional HDMI connection to A/V Receiver shown but not required.

3 CONNECTING YOUR DCX SET-TOP

Connecting HDTV — Separate Video/Audio Connections

Cable In

Connect an RF coaxial cable to the cable wall outlet and the CABLE IN connector on the DCX set-top.

DVI

If your TV has a DVI input, use the DVI connection for your video, connect a HDMI-to-DVI adapter or cable to the HDMI out connector on the DCX set-top and the DVI-HDTV connector on your TV.

Note: A DVI connection supports only the video connection between the DCX set-top and the HDTV.

To connect your audio connections with your TV speakers, go to [Audio](#) on the next page.

To connect your audio connections for an A/V receiver, go to [Connecting an A/V Receiver — Audio](#).

Component Video (YPbPr)

Connect the component video cables to the Y, Pb, and Pr connectors on your HDTV and DCX set-top.

Note: This connection only supports the video connection between the DCX set-top and the HDTV.

Note: Be sure to match up each signal to the same connection on the TV, otherwise the colors will not appear correctly on your TV.

To connect your audio connections with your TV speakers, go to [Audio](#) on the next page.

To connect your audio connections for an A/V receiver, go to [Connecting an A/V Receiver — Audio](#).

3 CONNECTING YOUR DCX SET-TOP

Audio

If your TV does not have digital audio inputs, connect the stereo audio cable to the AUDIO L/R connectors on the DCX3200 set-top and the AUDIO L/R connectors on the HDTV.

If your TV supports digital audio inputs, use the digital audio OPTICAL S/PDIF or COAXIAL S/PDIF outputs instead of the AUDIO L/R outputs. In most cases, S/PDIF offers better audio quality, including support for Dolby® Digital Plus audio.

For information on configuring your DCX set-top settings, go to [*Configuring the Audio, Video, and Closed Caption Settings.*](#)

3 CONNECTING YOUR DCX SET-TOP

Connecting Your DCX Set-top to an HDTV — Separate Video/Audio

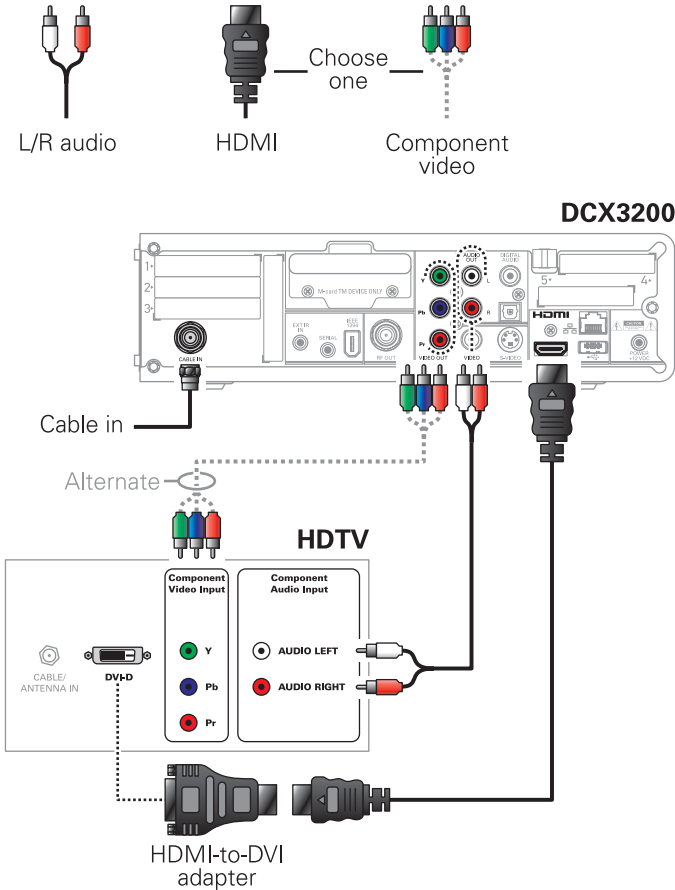

Note: Only (1) video connection and (1) audio connection needs to be made to an HDTV.

Note: Solid lines indicate optimum connections.

Note: HDMI-to-DVI adapter is not included with the set-top.

3 CONNECTING YOUR DCX SET-TOP

Connecting Your DCX Set-top to an HDTV — Alternative Audio

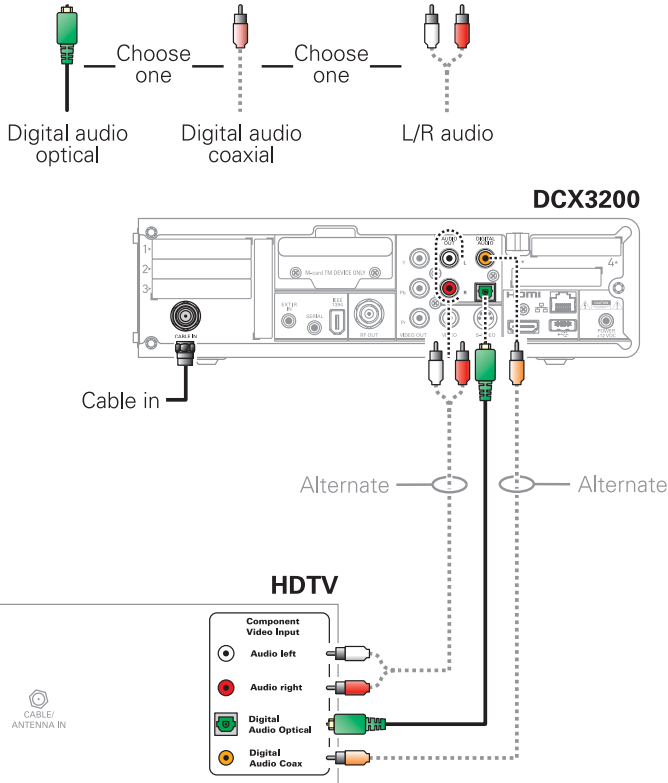

Note: Only (1) audio connection needs to be made.

Note: Solid lines indicate optimum connections.

3 CONNECTING YOUR DCX SET-TOP

Connecting an A/V Receiver — Audio

There are several options available for audio connections to your A/V receiver:

- Digital audio (OPTICAL S/PDIF)
- Digital audio (COAXIAL S/PDIF)
- Stereo audio (AUDIO L/R)

If your A/V receiver supports it, the optical (S/PDIF) or coaxial (S/PDIF) digital audio outputs may be used in place of the stereo audio outputs (AUDIO L/R). In most cases these outputs offer a higher level of audio quality, including support for Dolby Digital Plus audio.

- **Digital audio optical (S/PDIF)** — Connect the optical cable to the digital audio optical connector on the DCX set-top and the optical connector on the A/V receiver.
- **Digital audio coaxial (S/PDIF)** — Connect the digital audio cable to the digital audio coaxial connector on the DCX set-top and the DIGITAL INPUT COAX connector on the A/V receiver.
- **Stereo audio** — Connect the stereo audio cable to the AUDIO L/R connectors on the DCX set-top and the AUDIO L/R connectors on the A/V receiver.

For information on configuring your DCX set-top settings, see [*Configuring the Audio, Video, and Closed Caption Settings.*](#)

3 CONNECTING YOUR DCX SET-TOP

Connecting Your DCX Set-top to an A/V Receiver — Audio

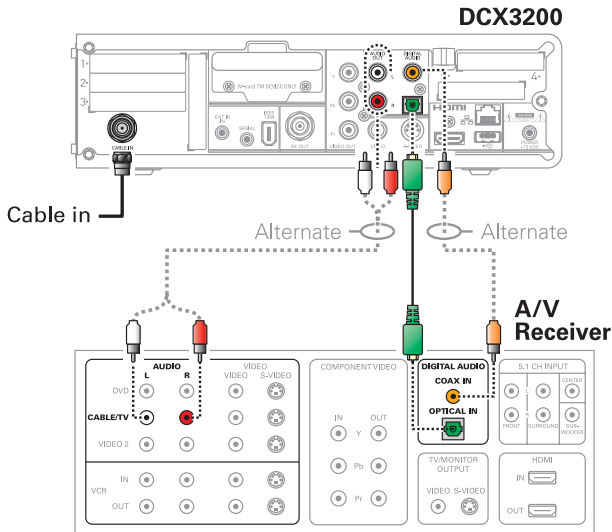
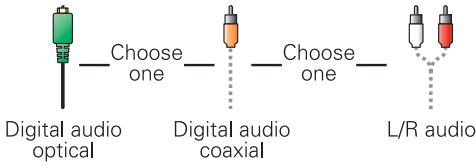

Note: Only (1) audio connection needs to be made to an A/V Receiver.

Note: Solid lines indicate optimum connections.

3 CONNECTING YOUR DCX SET-TOP

Connecting an SDTV

1. Connect the stereo audio cable to the AUDIO L/R connectors on the DCX set-top and the AUDIO L/R connectors on the Standard-Definition TV (SDTV).
2. Connect an S-Video cable to the S-Video out connector on the DCX set-top and the input S-Video on the TV.

Note: If the TV does not support S-Video connections, composite video connections may be used in place of S-Video connection.

Note: If the TV does not support S-Video or composite video connections, use the RF out connector on the DCX set-top. The RF connection carries video and audio.

These video connection methods do not support HD video. If you have an HDTV, see [Connecting HDTV — Single Connection for Video/Audio](#).

3 CONNECTING YOUR DCX SET-TOP

Connecting Your DCX Set-top to an SDTV

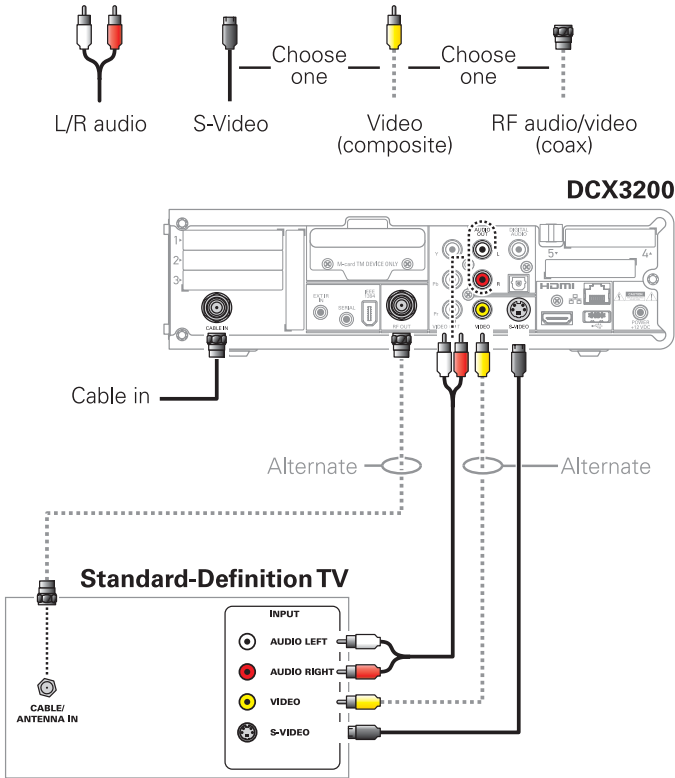

Note: S-Video and Composite video require separate audio connections.

Note: Only (1) video connection and (1) audio connection is required.

Note: Solid lines indicate optimum connections.

3 CONNECTING YOUR DCX SET-TOP

Connecting an SDTV and VCR/DVD Recorder

1. Connect a stereo audio cable to the AUDIO L/R connectors on the DCX3200 set-top and the INPUT AUDIO L/R connectors on the VCR/DVD recorder.
2. Connect a composite video cable to the VIDEO OUT connector on the DCX3200 set-top and the INPUT VIDEO connector on the VCR/DVD recorder.
3. Connect a stereo audio cable to the OUTPUT AUDIO L/R connectors on the VCR/DVD recorder and the INPUT AUDIO LEFT and RIGHT connectors on the Standard-Definition TV (SDTV).
4. Connect a composite video cable to the output video connector on the VCR/DVD recorder and the input video connector on the Standard-Definition TV (SDTV).

Note: You can also connect using the S-Video connectors if supported by your VCR/DVD recorder and SDTV.

These video connection methods do not support HD video. If you have an HDTV, see [Connecting HDTV — Single Connection for Video/Audio](#).

3 CONNECTING YOUR DCX SET-TOP

Connecting Your DCX Set-top to an SDTV and VCR/DVD Recorder

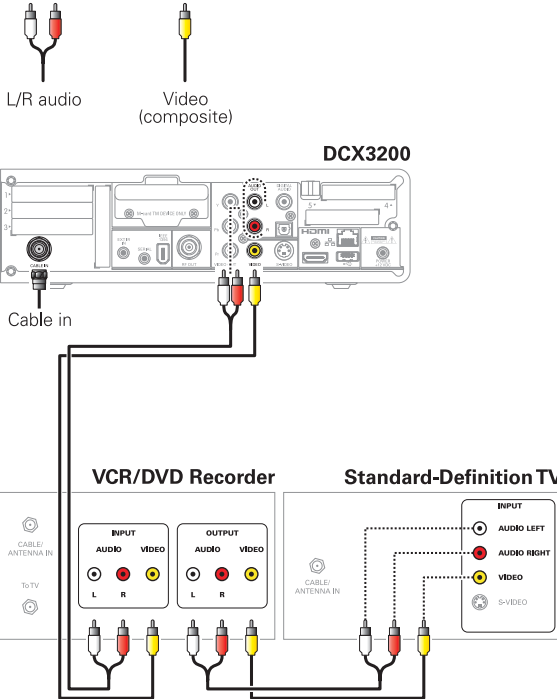

3 CONNECTING YOUR DCX SET-TOP

Connecting an A/V Receiver, SDTV, and VCR/DVD Recorder

1. Connect a stereo audio cable to the AUDIO OUT L/R connectors on the DCX set-top and the INPUT L/R connectors on the A/V receiver.
2. Connect an S-Video cable to the S-Video out connector on the DCX set-top and the S-Video connector on the A/V receiver.

Note: If your A/V Receiver does not support S-Video connections, Composite video connections may be used in place of the S-Video connection.

3. Connect a stereo audio cable to the VCR/DVD recorder AUDIO OUT L/R connectors on the A/V receiver and the INPUT AUDIO L/R connectors on the VCR/DVD recorder.
4. Connect a stereo audio cable to the AUDIO OUT L/R connectors on the VCR/DVD recorder and the VCR AUDIO IN L/R connectors on the A/V receiver.
5. Connect a composite video cable to the INPUT VIDEO connector on the VCR/DVD recorder and the composite video VCR OUT connector on the A/V receiver.
6. Connect a composite video cable to the composite VIDEO OUT connector on the VCR/DVD recorder and the video VCR IN connector on the A/V receiver.
7. Connect a S-Video cable to the S-Video connector in on the Standard-Definition TV (SDTV) and the TV/monitor S-Video out connector on the A/V receiver.

Note: If your TV or A/V receiver does not support S-Video connections. Composite video connections may be used in place of S-Video connection.

Note: The digital optical audio (OPTICAL S/PDIF) or digital coaxial audio (COAXIAL S/PDIF) outputs may be used in place of the stereo audio outputs (AUDIO L/R). In most cases these outputs offer a higher level of audio quality, including support for Dolby Digital Plus audio.

These video connection methods do not support HD video. If you have an HDTV, see [Connecting HDTV — Single Connection for Video/Audio](#).

3 CONNECTING YOUR DCX SET-TOP

Connecting Your DCX Set-top to an A/V Receiver, SDTV, and VCR/DVD Recorder

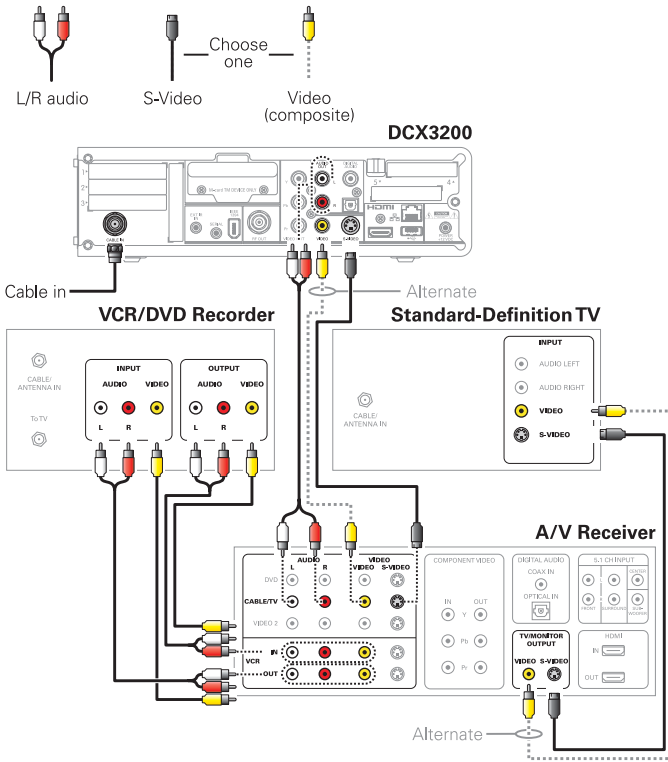

Note: Solid lines indicate optimum connections.

Note: Consult your A/V receiver manual for additional wiring options or constraints when including a VCR/DVD recorder in your configuration.



4 RECORDING YOUR CONNECTIONS

Use this diagram to record connections between your home entertainment components. You can use this diagram to reconnect your system if you move the equipment or add new equipment.

Disconnect the power from the DCX set-top before connecting or changing cable connections. Do not place another component or object on top of the DCX set-top.

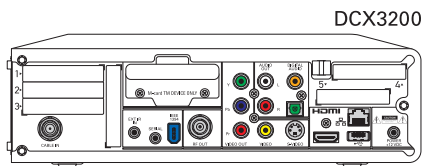

VCR

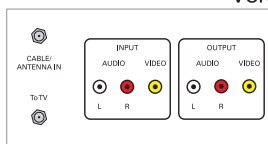

HDTV / Standard-Definition TV

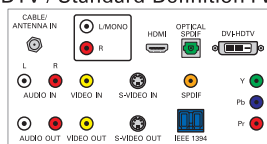

Audio receiver

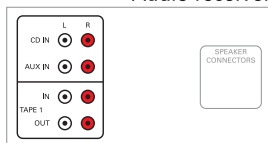

DVD

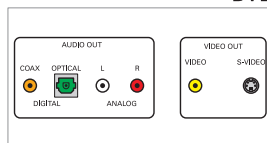

A/V receiver

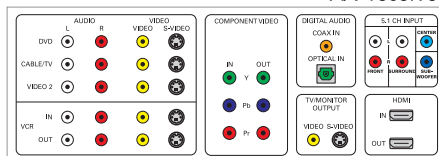

4 RECORDING YOUR CONNECTIONS

Data Devices

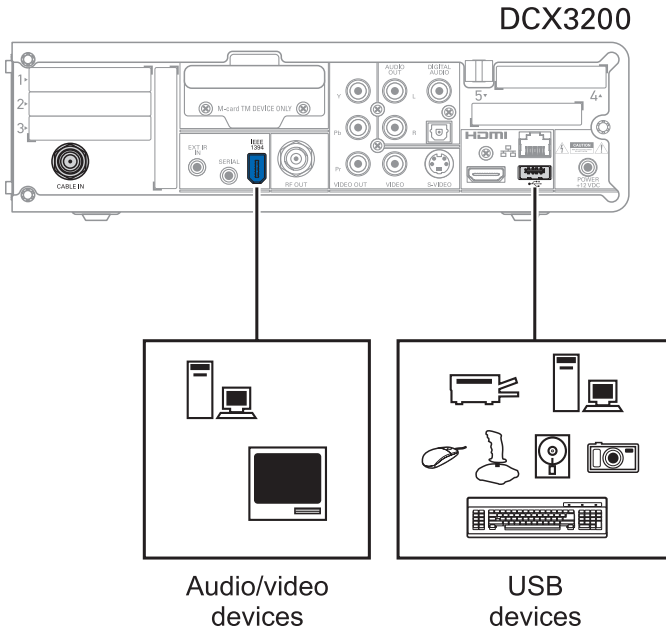

Note: Do not attempt to connect data devices without contacting your service provider. Advanced data features require the proper application and network infrastructure to operate.

Data Features

In addition to high-quality audio and video, the DCX set-top has the capability to deliver high-speed data services such as Internet access, e-mail, IP telephony, e-commerce, and home banking.

Note: Your DCX set-top may be equipped with the interface connections illustrated, but their functionality depends on the services offered by your service provider.



5 ON-SCREEN GRAPHICS

Your DCX set-top can generate graphics that overlay the video programming or fill the entire television screen. Common examples include on-screen menus (such as the User Setting menu), closed captions, and interactive program guides. The DCX set-top overlays these graphics whenever you open a menu, enable closed captions, or scroll through a program grid.

- On-screen graphics are not available on all video output combinations.
- On-screen graphics will not be displayed when you are using the IEEE-1394 connection on the rear panel of the DCX set-top.



6 CONFIGURING THE AUDIO, VIDEO, AND CLOSED CAPTION SETTINGS

The following describes how to configure the audio (for HDMI connections), SD and HD video settings, and closed caption settings for the DCX3200.

Before you adjust the output settings:

- Connect the DCX3200 to the TV and other home entertainment devices
- Plug the DCX3200 into an AC power outlet
- Initialize the DCX3200 and authorize it for services
- Turn the TV on

When using an HDMI connection between the DCX3200 and the television, be sure to have the cable connected and the TV powered on before adjusting the video settings. Motorola recommends using HDMI cables less than 20 meters long.

To configure the DCX3200 settings on the User Settings menu screen:

1. Power off the DCX set-top and then immediately press the menu key on the remote control. If your TV is on, the on-screen User Settings menu lists the DCX3200 settings that can be adjusted:

6 CONFIGURING THE AUDIO, VIDEO, AND CLOSED CAPTION SETTINGS

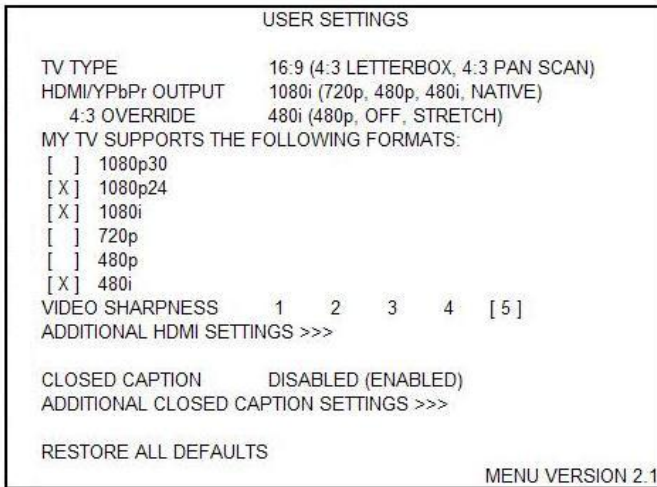

An example of the User Settings menu when the HDMI output is connected.

Note: The User Settings menu indicates whenever an HDMI connection is in place between the DCX3200 and another device.

6 CONFIGURING THE AUDIO, VIDEO, AND CLOSED CAPTION SETTINGS

When the HDMI connection is not being used the User Settings Menu will update to reflect this:

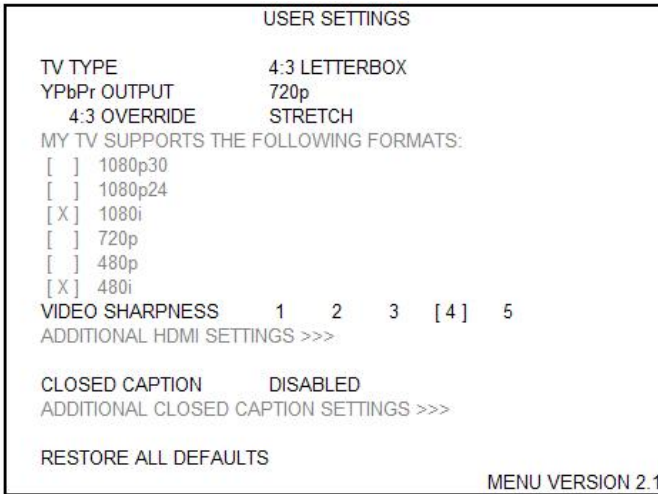

An example of the User Settings menu when the HDMI output is not connected.

2. Use your remote control to navigate the on-screen display:
 - Press the ▲ and ▼ keys to highlight the setting you wish to change.
 - Press the ► key to select an option for that setting.
 - To exit the setting and move to another setting, use the ▲ and ▼ keys.
 - To exit the menu and save your settings, press the POWER or MENU key.

If the User Settings menu does not display on the HDTV Screen, the TV may not support the default video output settings. Use the Format button on the front panel to select a video output format that can be displayed by the TV as described in "There is no video on the TV screen" in the [Troubleshooting](#) section.

6 CONFIGURING THE AUDIO, VIDEO, AND CLOSED CAPTION SETTINGS

The User Settings option follow:

Setting	Description
TV Type	<p>The TV Type allows you to specify the style of television connected to the DCX3200. Options include 16:9, 4:3 LETTERBOX, and 4:3 PAN SCAN. By default, the 16:9 option is selected. The options are used as follows:</p> <ul style="list-style-type: none"><li data-bbox="362 402 859 451">• 16:9 designates that a widescreen television is connected to the DCX3200.<li data-bbox="362 472 908 570">• 4:3 LETTERBOX designates that a standard-screen television is connected to the DCX3200 and that widescreen programs should be scaled to fit the screen with black bars above and below the picture.<li data-bbox="362 591 912 688">• 4:3 PAN SCAN designates that a standard screen television is connected to the DCX3200 and that widescreen programs should be cropped so that the picture fills the entire screen.

6 CONFIGURING THE AUDIO, VIDEO, AND CLOSED CAPTION SETTINGS

Setting	Description
HDMI / YPbPr Output	<p>The HDMI/YPbPr Output setting allows you to specify the video output format of the DCX3200 for all programs (when the 4:3 Override setting is set Off or Stretch) or for all widescreen programs (when the 4:3 Override is set to 480i or 480p). Options include 1080i, 720p, 480p, 480i, and Native. By default, the 1080i option is selected.</p> <p>The options are used as follows:</p> <ul style="list-style-type: none"> • 1080i — The DCX3200 will present programs in the High-Definition 1080i format (1920 x 1080 pixels with interlaced scanning at 30 frames per second). • 720p — The DCX3200 will present programs in the High-Definition 720p format (1280 x 720 pixels with progressive scanning at 60 frames per second). • 480p — The DCX3200 will present programs in the Enhanced-Definition 480p format (720 x 480 pixels with progressive scanning at 60 frames per second). • 480i — The DCX3200 will present programs in the Standard-Definition 480i format (720 x 480 pixels with interlaced scanning at 30 frames per second). • Native — The DCX3200 will present programs in the format that most closely matches their native format according to the compatible formats selected from the “My TV Supports The Following Formats” list (see below). 1080p 24/30 will be presented natively. <p><u>Note 1:</u> Some televisions may only support certain video formats. Please consult the television’s user manual for more information on video format compatibility.</p> <p><u>Note 2:</u> The DCX3200 can detect when the HDMI connection is in use. If you are not using the HDMI connection on the DCX3200, the “HDMI/YPbPr Output” setting will display as “YPbPr Output” in the User Settings Menu.</p>

6 CONFIGURING THE AUDIO, VIDEO, AND CLOSED CAPTION SETTINGS

Setting	Description
4:3 Override	<p>The 4:3 Override setting allows you to specify the video output format of the DCX3200 when it is tuned to a Standard-Definition program or playing back a Standard- Definition program from the DVR. Options include 480i, 480p, Stretch, and Off. By default, the 480i option is selected.</p> <p>The options are used as follows:</p> <ul style="list-style-type: none">• 480i — The DCX3200 will present Standard-Definition programs in the Standard-Definition 480i format (720 x 480 pixels).• 480p — The DCX3200 will present Standard-Definition programs in the Enhanced-Definition 480p format (720 x 480 pixels).• Stretch — The DCX3200 will automatically stretch all Standard-Definition programs to a widescreen aspect ratio and present the video in the format designated by the HDMI/YPbPr Output setting. Note that the Stretch option is only available when the TV Type setting is 16:9.• Off — The DCX3200 will create a widescreen version of a Standard-Definition program by adding black bars to the left and the right of the picture and present the video in the format designated by the HDMI/YPbPr Output setting. <p><u>Note 1:</u> Some televisions may only support certain video formats. Please consult your television’s user manual for more information on format compatibility.</p> <p><u>Note 2:</u> If the HDMI/YPbPr Output setting is set to either 480i or Native, the 4:3 Override feature is disabled and is no longer selectable in the menu. The 4:3 Override feature is available when the HDMI/YPbPr Output setting is 1080i, 720p, or 480p.</p>

6 CONFIGURING THE AUDIO, VIDEO, AND CLOSED CAPTION SETTINGS

Setting	Description
My TV Supports The Following Formats	<p>The My TV Supports The Following Formats checklist allows you to configure the Native mode operation of the DCX3200. The checklist becomes accessible only when the HDMI/YPbPr Output setting is set to Native. The DCX3200 is capable of delivering all of the video formats listed in this checklist depending upon the type of video connection (HDMI or YPbPr) being used. By default, the 1080i and 480i formats are checked in this checklist.</p> <p>The options are used as follows:</p> <ul style="list-style-type: none"> • 1080p30 – The DCX3200 will present programs broadcast in the High Definition 1080p30 format (1920 x 1080 pixels with progressive scanning at 30 frames per second) using the HDMI connection only. The DCX3200 cannot convert any other broadcast format to the 1080p30 format. • 1080p24 - The DCX3200 will present programs broadcast in the High Definition 1080p24 format (1920 x 1080 pixels with progressive scanning at 24 frames per second) using the HDMI connection only. The DCX3200 cannot convert any other broadcast format to the 1080p24 format. • 1080i – The DCX3200 will present programs broadcast in the High Definition 1080i format using both the HDMI and YPbPr connections. The DCX3200 can also convert any other broadcast format to the 1080i format. • 720p – The DCX3200 will present programs broadcast in the High Definition 720p format using both the HDMI and YPbPr connections. The DCX3200 can also convert any other broadcast format to the 720p format. • 480p – The DCX3200 will present programs broadcast in the Enhanced Definition 480p format using both the HDMI and YPbPr connections. The DCX3200 can also convert any other broadcast format to the 480p format. • 480i – The DCX3200 will present programs broadcast in the Standard Definition 480i format using both the HDMI and YPbPr connections. The DCX3200 can also convert any other broadcast format to the 480i format. <p><u>Note 1:</u> The DCX3200 cannot provide 1080p30 or 1080p24 video using the YPbPr output. When using the DCX3200 in Native mode, these two formats are disabled and inaccessible if there is no HDMI connection in place.</p>

6 CONFIGURING THE AUDIO, VIDEO, AND CLOSED CAPTION SETTINGS

Setting	Description
	<p><u>Note 2:</u> When connecting the DCX3200 to an HDMI (or DVI) TV, the TV provides the DCX3200 with its list of supported video formats. The DCX3200 will automatically place a check next to the formats in the checklist that it can verify are supported by the TV. The checklist may be modified manually after the DCX3200 performs the automatic configuration.</p> <p><u>Note 3:</u> While this checklist provides the ability to customize the Native mode experience when using the DCX3200, it can also result in a loss of video if the checklist is modified without a clear understanding of the video formats supported by the TV. These settings should only be modified by a professional installer or someone with a good working knowledge of the video formats supported by the TV.</p> <p><u>Note 4:</u> When using the DCX3200 in Native mode, at least one of the following formats (1080i, 720p, 480p, 480i) MUST be checked even if one or both of the 1080p formats has been checked. The DCX3200 cannot be configured to provide video only in the 1080p30 and/or 1080p24 formats. The DCX3200 also does not support the 1080p60 video format.</p> <p><u>Note 5:</u> The DCX3200 will provide 480i format video on the YPbPr output whenever 1080p30 or 1080p24 format video is being provided on the HDMI output.</p>
Video Sharpness	<p>The Video Sharpness setting allows you to adjust the picture sharpness when viewing a standard definition (SD) program on the DCX3200. The Video Sharpness setting affects all of the video outputs. By default, the sharpness level of 3 is selected.</p> <p>The DCX3200 supports five distinct levels of video picture sharpness. A value of 1 corresponds to a “softer” picture while a value of 5 corresponds to a “sharper” picture. The best sharpness setting depends upon the video connection being used, the display quality of the TV, and the viewer’s personal preference.</p>
Additional HDMI Settings	<p>The Additional HDMI Settings option is available whenever an HDMI connection is in place. Selecting this option will present a new menu screen with settings specific to the HDMI connection. These settings are discussed in more detail on the following pages.</p>
Closed Caption	<p>The Closed Caption setting turns closed captions off or on. When this option is set to Disabled, the DCX3200 does not render (draws) closed captions on any video output. When this option is set to Enabled, the DCX3200 renders (draws) closed captions on all video outputs. By default, the Disabled option is selected.</p>

6 CONFIGURING THE AUDIO, VIDEO, AND CLOSED CAPTION SETTINGS

Setting	Description
Additional Closed Caption Settings	The Additional Closed Caption Settings option is available whenever the Closed Caption setting is set to Enabled. Selecting this option will present a new menu screen with settings specific to closed captions. These settings are discussed in more detail on the following pages.
Restore All Defaults	To reset all User Settings to their default values, move the cursor to this option and press the ► key.

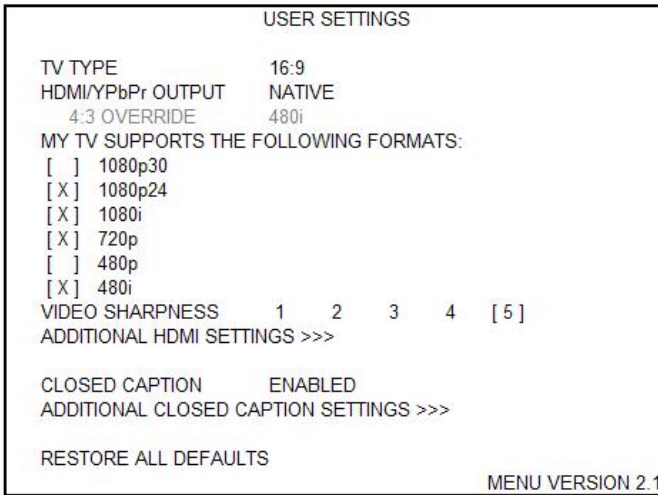

An example of the User Settings menu when configured for Native mode operation.

To configure the DCX3200 settings on the Additional HDMI Settings menu screen:

1. With an HDMI connection in place, power off the DCX3200 and then immediately press the MENU key on the front panel.
2. This will display the main User Settings menu.
3. Move the cursor next to the “Additional HDMI Settings” option and press the ► key.

6 CONFIGURING THE AUDIO, VIDEO, AND CLOSED CAPTION SETTINGS

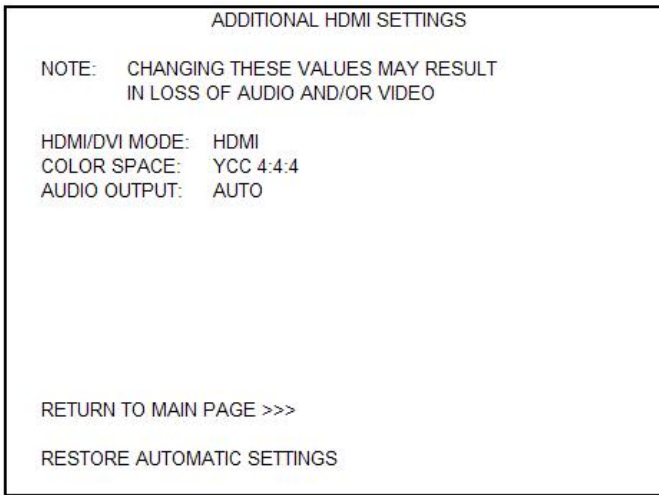

An example of the Additional HDMI Settings menu.

The Additional HDMI Settings menu options are:

Setting	Description
HDMI/DVI Mode	<p>The HDMI/DVI mode settings allows you to optimize the HDMI output to work with both DVI-equipped televisions and HDMI equipped televisions. By default, this option is set to HDMI. The options are used as follows:</p> <ul style="list-style-type: none">• HDMI designates that an HDMI television is connected to the DCX3200.• DVI designates that a DVI television is connected to the DCX3200 (via an HDMI-to-DVI adapter).
Color Space	<p>The Color Space setting allows you to adjust the color space used by the DCX3200 to generate the video signals on the HDMI output. By default, this option is set to YCC 4:4:4. The options are used as follows:</p> <ul style="list-style-type: none">• YCC 4:4:4 designates that the DCX3200 will generate video signals within the YCC color space.• RGB designates that the DCX3200 will generate video signals within the RGB color space. <p>Note 1: Adjusting these settings could result in a loss of video. Only a professional installer or someone with a good working knowledge of the color spaces supported by the TV should change this setting.</p>

6 CONFIGURING THE AUDIO, VIDEO, AND CLOSED CAPTION SETTINGS

Setting	Description
Audio Output	<p>The Audio Output setting allows you to specify the digital audio format delivered over the HDMI connection by the DCX3200. Options include Auto, L-PCM, and Pass Through. By default, the Auto option is selected. The options are used as follows:</p> <ul style="list-style-type: none"> • Auto designates that the DCX3200 will provide the digital audio format specified by the connected device (TV or home theater receiver) when that device was first connected to the DCX3200. • L-PCM designates that the DCX3200 will provide all audio in the Linear Pulse Code Modulation digital audio format. The L-PCM format is widely supported by most HDMI televisions and home theater receivers. • Pass Through designates that the DCX3200 will provide the same digital audio format on the HDMI output as is provided with the program being viewed at that time. For example, if the program has a Dolby Digital soundtrack, the DCX3200 will pass the Dolby Digital audio to the HDMI output. This option is most useful when connecting the DCX3200 to a home theater receiver that has HDMI switching capability. <p><u>Note 1:</u> Adjusting these settings could result in a loss of audio. Only a professional installer or someone with a good working knowledge of the digital audio formats supported by the TV and/or home theater receiver should change this setting.</p>
Return To Main Page	Selecting this option will return you to the main User Settings menu screen.
Restore Automatic Settings	Selecting this option will restore all of the settings on this screen (HDMI/DVI Mode, Color Space, and Audio Output) to their default value. Use this option if audio and/or video has been lost after adjusting these settings from their default values.

To configure the DCX3200 settings on the Additional Closed Caption Settings menu screen:

1. Power off the DCX3200 and then immediately press the MENU key on the front panel. This will display the main User Settings menu.
2. Move the cursor next to the "Closed Caption" option and adjust this setting to "Enabled."
3. The option to enter the Additional Closed Caption Settings menu is now available.

6 CONFIGURING THE AUDIO, VIDEO, AND CLOSED CAPTION SETTINGS

ADDITIONAL CLOSED CAPTION SETTINGS	
SERVICE SELECTION	
ANALOG	CC1
DIGITAL	PRIMARY LANGUAGE
FONT SIZE	AUTO
FONT STYLE	AUTO
FONT COLOR	AUTO
FONT OPACITY	AUTO
FONT EDGE TYPE	AUTO
FONT EDGE COLOR	AUTO
BACKGROUND COLOR	AUTO
BACKGROUND OPACITY	AUTO
SETTINGS	AUTO
RETURN TO MAIN PAGE >>>	
RESTORE CLOSED CAPTION DEFAULTS	

An example of the Additional Closed Caption Settings menu.

6 CONFIGURING THE AUDIO, VIDEO, AND CLOSED CAPTION SETTINGS

The Additional Closed Caption Settings menu options are:

Setting	Description
Service Selection	<p>Sets the service used by the DCX3200 to render (draw) the closed captions:</p> <ul style="list-style-type: none"> • Analog: CC1, CC2, CC3, CC4, T1, T2, T3, or T4. The default is CC1. • Digital: PRIMARY LANGUAGE, SECONDARY LANGUAGE, 3, 4, 5, or 6. The default is PRIMARY LANGUAGE.
Font Size	Sets the font size for closed captions. Defaults to AUTO. Options are AUTO, STANDARD, LARGE, or SMALL.
Font Style	Sets the font style for closed captions. Defaults to AUTO. Options are AUTO, MONO SERIF, PROPORTION SERIF, MONO NO SERIF, PROPORTION NO SERIF, CASUAL, CURSIVE, or SMALL.
Font Color	Sets the font color. Defaults to AUTO. Options are AUTO, WHITE, BLACK, RED, GREEN, BLUE, YELLOW, MAGENTA, or CYAN.
Font Opacity	Sets the opacity. Defaults to AUTO. Options are AUTO, TRANSPARENT, TRANSLUCENT, SOLID, or FLASHING.
Font Edge Type	Sets the edge appearance — AUTO, NONE, RAISED, DEPRESSED, UNIFORM, LEFT SHADOWED, or RIGHT SHADOWED. The default is AUTO.
Font Edge Color	Sets the edge color — AUTO, WHITE, BLACK, RED, GREEN, BLUE, YELLOW, MAGENTA, or CYAN. The default is AUTO.
Background Color	Sets the background color for closed captions. Defaults to AUTO. Options are AUTO, WHITE, BLACK, RED, GREEN, BLUE, YELLOW, MAGENTA, or CYAN.
Background Opacity	Sets the background opacity for closed captions. Defaults to AUTO. Options are AUTO, TRANSPARENT, TRANSLUCENT, SOLID, or FLASHING.
Settings	Sets the default settings for closed captions (AUTO) or the settings you have configured (USER). Defaults to AUTO. Options are AUTO or USER.
Return To Main Page	Selecting this option will return you to the main User Settings menu screen.
Restore Closed Caption Defaults	To reset all of the Additional Closed Caption settings to their default values, select this option and press the ► key.



7 TROUBLESHOOTING

Before calling your service provider, review this troubleshooting guide. This information is to help you quickly solve a problem. If your problem still exists, contact your service provider.

Problem	Possible Solution
The DCX set-top will not power on	<p>The DCX set-top may have received a software update and may not power on while the new software is being installed. Try again in a few minutes.</p> <ul style="list-style-type: none">• Verify that the AC power cord of the external power supply is connected to the DCX set-top and an AC outlet. Unplug the DCX set-top from the AC outlet, plug it back in, and then press the POWER button.• If the DCX set-top is connected to a switched outlet on another unit, verify that that unit is powered on. Unplug the power cord from the DCX set-top's AC outlet, plug it back in, and then press the POWER button. It is recommended to use an unswitched outlet, if possible.• Press the POWER button on the DCX set-top remote control. The batteries in the remote control may be depleted.
The remote control does not work	<p>Verify that the remote control is in "Cable" mode.</p> <p>Verify that there are no obstructions between the remote control and the DCX set-top. Aim the remote control directly at the DCX set-top front panel, not the TV or VCR.</p> <p>The angle between the remote control and the DCX set-top may be too large. Stand in front of the DCX set-top and not too far to either side.</p> <ul style="list-style-type: none">• Press and release operation keys one at a time, firmly and deliberately.• Check the batteries in the remote control. Install new batteries if needed.

7 TROUBLESHOOTING

Problem	Possible Solution
There is no audio when viewing cable channels	<p data-bbox="263 237 939 310">Verify that the mute button on the DCX set-top or the remote control has not been pressed. Press mute on the remote control to restore sound.</p> <ul data-bbox="362 331 939 683" style="list-style-type: none"><li data-bbox="362 331 939 407">• If the DCX set-top audio output is connected to the TV, verify that the mute button on the TV has not been pressed.<li data-bbox="362 423 939 526">• If the DCX set-top audio output is connected to a home theater receiver, verify that the receiver is set to the appropriate input source and the mute button on the receiver has not been pressed.<li data-bbox="362 542 939 591">• Verify that you have the correct cables for the audio connections.<li data-bbox="362 607 939 683">• Verify that the audio cables are firmly connected between the DCX set-top and the audio playback device (TV, receiver, DVD player, etc.).
There is no audio from the center and/or surround speakers of a home theater receiver connected to the DCX set-top	<p data-bbox="263 708 939 781">Not all Dolby Digital® programs feature full 5.1 or 7.1 surround sound. In some cases, the programs may only contain left and right stereo audio.</p> <ul data-bbox="362 802 939 1036" style="list-style-type: none"><li data-bbox="362 802 939 878">• Verify that the S/PDIF (coaxial or optical) audio cable is firmly connected to the DCX set-top and the home theater receiver.<li data-bbox="362 894 939 971">• Verify that the home theater receiver is set to a surround sound audio mode (Dolby Digital, Dolby Pro Logic II®, Dolby Pro Logic®, Dolby Digital Plus®).<li data-bbox="362 987 939 1036">• Verify that the receiver is properly configured to work with all connected speakers.

7 TROUBLESHOOTING

Problem	Possible Solution
There is no video on the TV screen	<p>Verify that the TV is powered on and set to the appropriate input source for the DCX set-top.</p> <p>Verify that the DCX set-top is powered on and tuned to an authorized cable channel.</p> <p>Verify that all video cables between the DCX set-top and the TV are firmly connected.</p> <p>Verify that the coaxial cable feed is firmly connected to the DCX set-top and the wall jack.</p> <ul style="list-style-type: none"> • If the DCX set-top video output is connected to a home theater unit, verify that the home theater unit is powered on and set to the appropriate input source. • If the DCX set-top video output is connected to a TV through an HDMI connection, power off the TV and then power off the DCX set-top. Wait one second and then power on the devices. <p>Not all HDTVs can display every output format (1080p, 1080i, 720p, 480p, or 480i) available on the DCX set-top. To select a different format:</p> <ol style="list-style-type: none"> 1. Ensure that your DCX set-top is plugged into a power outlet and is turned off. 2. Press Menu button on the remote control. 3. Press the ▲ and ▼ keys to display the HDMI/YPbPr OUTPUT setting. 4. Press the ► key to cycle through the available output formats until a picture displays on the TV.
No graphics or program guides appear on the TV screen	<p>If you use the IEEE-1394 connection, on-screen graphics, including closed captions and program guides, are not displayed by the DCX set-top. On-screen graphics and captions may still be overlaid by your TV, if enabled. Alternatively, use HDMI or component video instead.</p>
No closed captions display	<p>Verify on the User Settings menu that closed captions are enabled on the DCX set-top.</p> <p>Verify that closed captions are enabled on the TV.</p> <p>Note: Closed captioning may not be available on the current program.</p>

7 TROUBLESHOOTING

Problem	Possible Solution
<p>There are black bars to the right and left of the picture</p>	<p>Wide screen TVs display 4:3 programs in this format unless set to Stretch. Turn on the 4:3 OVERRIDE feature in the User Settings menu. This enables most wide screen TVs to stretch the video to fill the screen (see your TV manual for information about stretching 4:3 video).</p> <ul style="list-style-type: none"> • If the DCX3200 is connected to a wide screen TV, verify that the TV TYPE is set to 16:9 in the User Settings menu. <p>Many HD programs are broadcast in pillar-box format with black bars to the left and right of the picture. These programs are broadcast in 16:9 HD formats even though the video is not 16:9.</p>
<p>There are black bars above and below the picture</p>	<p>All 4:3 HDTVs display HD programs in letterbox format (black bars above and below the picture) because of the shape of the display screen.</p> <ul style="list-style-type: none"> • Turn on the 4:3 OVERRIDE feature in the User Settings menu. This enables most standard screen TVs to display a full screen picture when the DCX3200 is tuned to a 4:3 program. • Set the TV TYPE to 4:3 Pan-Scan. This enables the DCX3200 to remove the black bars above and below the picture when possible. <p>Some SD programs are broadcast in the letterbox format with black bars above and below the picture. Some widescreen TVs offer a zoom feature that may be able to remove the black bars (see your TV manual for information about zooming 4:3 video).</p>
<p>There are black bars on all four sides of the picture</p>	<p>This may occur on a 4:3 TV if the 4:3 OVERRIDE setting is OFF. To set 4:3 SD programming to fill the screen, depending on the capabilities of the TV, set 4:3 OVERRIDE to 480i or 480p.</p> <p>This may occur on a 16:9 TV if the active video for an SD broadcast is in letterbox format. To confirm, wait for a commercial or look for a graphic, such as a network logo. If the commercial fills the screen from top to bottom, or the graphic appears below the active video, the program is being letterboxed by the broadcaster. You can minimize this by activating the zoom feature on the TV.</p> <p>A broadcaster may include black bars on either side of a wide screen broadcast. This is called a "hybrid" aspect ratio and results in a black border surrounding the video on a 4:3 TV. Because this is part of the broadcast, the DCX3200 cannot correct the video. You may be able to minimize the border using the zoom feature on the TV.</p>
<p>Colors do not appear correctly</p>	<p>Be sure to match up each signal to the same YPbPr connection on the TV, otherwise the colors will not appear correctly on your TV.</p>



Motorola, Inc.
101 Tournament Drive
Horsham, PA 19044 U.S.A.

<http://www.motorola.com>

547052-001-a
05/08